

# **MODEL B**

## **INSTALLATION & MAINTENANCE**



## ADDRESS AND CONTACT DATA

Heatex AB  
Bronsyxegatan 13  
S-213 75 MALMÖ  
Sweden  
Telephone: +46 410 710 500  
info@heatex.com  
www.heatex.com

## DISCLAIMER

Information in this document (including URL references and information from other external sources referred herein) is subject to change without notice. Owing to continued product development, Heatex reserves the right to introduce alterations in both design and prices without prior notice.

THIS DOCUMENT IS PROVIDED "AS IS" WITH NO EXPRESSED OR IMPLIED WARRANTIES WHATSOEVER, INCLUDING ANY WARRANTY OF MERCHANTABILITY, NON-INFRINGEMENT, FITNESS FOR ANY PARTICULAR PURPOSE, OR OTHERWISE ANY WARRANTY ARISING OUT OF ANY PROPOSAL, SPECIFICATION OR SAMPLE. ALL LIABILITY, INCLUDING LIABILITY FOR INFRINGEMENT OF ANY PROPRIETARY RIGHTS, RELATING TO USE OF INFORMATION CONTAINED OR REFERENCED IN THIS DOCUMENT IS HEREBY EXPRESSLY DISCLAIMED.

## COPYRIGHT NOTICE

All information and content included (whether directly or by reference) in this document, such as text, graphics and images, is the property of Heatex AB, its subsidiaries, affiliates, licensors and/or joint venture partners. All rights are reserved.

No licenses, express, implied or otherwise to any intellectual property rights in this document are granted by Heatex AB.

This disclaimer and copyright notice is subject to and governed by Swedish law.

Copyright © 2016

Heatex AB

## DECLARATION OF INCORPORATION

Description and identification of the partly completed machinery:

### **Rotary heat exchanger model B with casing and with a drive unit.**

The following essential requirements of EC Machinery Directive 2006/42/EC have been applied and fulfilled:

1.1.2, 1.2.1, 1.2.3, 1.2.4.1, 1.2.4.2, 1.2.4.3, 1.2.6, 1.3.1, 1.3.2, 1.3.4, 1.3.7, 1.3.8, 1.3.8.1, 1.3.8.2, 1.4.1, 1.4.2.1, 1.4.2.2, 1.4.2.3, 1.4.3, 1.5.1, 1.5.2, 1.5.4, 1.5.5, 1.5.6, 1.6.1, 1.6.3, 1.7.1, 1.7.3, 1.7.4, 1.7.4.1, 1.7.4.2, 1.7.4.3

The relevant technical documentation has been compiled in accordance with Annex VII, Part B of EC Machinery Directive 2006/42/EC. We undertake, in response to a reasoned request, to supply it in electronic form to the market surveillance authorities within a reasonable period.

The party authorized to compile the technical documentation is:

Johan Gidner, R&D Manager

The partly completed machinery must not be put into service until the final machinery into which it is to be incorporated has been declared in conformity with the provisions of the Machinery Directive.

Malmö, 2014-07-18



---

Knud Foldschack  
CEO

## CONTENT

|   |   |
|---|---|
| 1. GENERAL  | 5 |
| 2. AT DELIVERY  | 5 |
| 2.1. Transport  | 5 |
| 3. STORAGE  | 5 |
| 4. INSTALLATION   | 6 |
| 5. ADJUSTMENTS  | 6 |
| 6. MAINTENANCE  | 7 |
| 6.1. Matrix   | 7 |
| 6.2. Hybrid/Adsorption Material                                   | 7 |
| 6.3. Powerbelt  | 7 |
| 6.4. Round Belt   | 7 |
| 6.5. Brush Sealings   | 7 |
| 6.6. Controller   | 7 |
| 6.7. Application Limits   | 8 |
| 6.8. Troubleshooting  | 8 |
| 6.9. Conditions to Fulfill the Hygiene Certification Requirements | 9 |
| 7. SUPPORT  | 9 |

## 1. GENERAL

A rotary heat exchanger with casing and drive is “partly completed machinery” as defined in Directive 2006/42/EC. This product is delivered in compliance with the Directive 2006/42/EC but when installed in the complete machinery it is up to the installer to make sure that the final product complies with the directive.

Special attention should be paid to sharp edges (risk of cuts) and that when the wheel is rotating the rotating parts may cause injuries.

The surfaces of the drive motor and gear can be hot and attention should be paid to the risk of burn injuries.

The sound level from the heat exchanger is less than 70 dB (A).

## 2. AT DELIVERY

Before installation, the following should be checked:

- Check if there are any signs of transport damage before accepting the goods.
- Has the right exchanger been delivered? Check type, design, size and options.
- How is the exchanger to be positioned?
- In case of any damage, please report this in writing by fax or email as soon as possible.

### 2.1. Transport

- The weight of the unit can be found on the product label attached to the unit
- Always transport the exchanger vertically.
- Lift the exchanger in the upper two aluminum rods alternatively the gables according to picture 1.
- It is important that all transport is carried out by qualified staff.



All transport and handling shall be carried out by qualified staff.

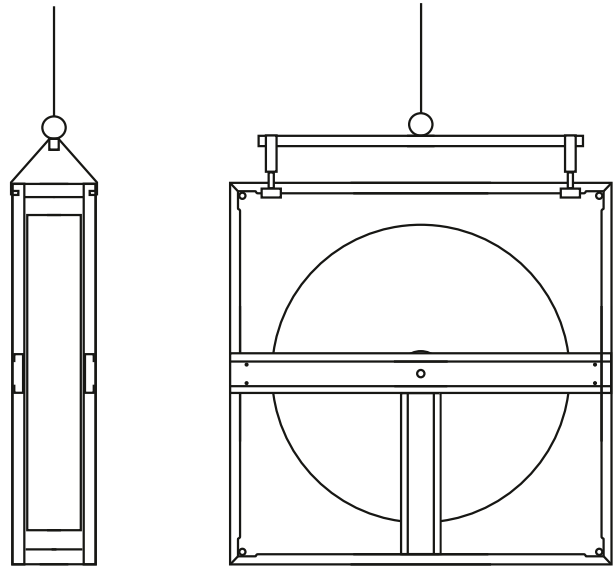

Picture 1. Lift the casing at the gables.

## 3. STORAGE

There are no other requirements for storage than a horizontal even surface and out of weather. Please note that an uneven surface can warp the cassette and affect the factory adjustments.

Always make sure that the heat exchanger is supported and secured during transport, handling, storage and installation so it cannot fall over and cause damage or injuries.



Heat exchanger may fall over if not secured.

Please observe that there may be sharp edges and a risk for cuts so we recommend that gloves be used when the heat exchanger is handled.



Use gloves when handling the heat exchanger.

## 4. INSTALLATION

- When designing the air handling unit and/or duct system, the system designer needs to make sure it is possible to remove/pull out the heat exchanger for inspection, maintenance, service, cleaning and disinfection. Furthermore, the system designer needs to consider enough space inside and outside of the system to make sure that it is possible to remove/pull out the heat exchanger.
- For bigger heat exchanger units it is required to add doors or hatches on all sides in the air-handling unit and/or duct system making it possible to access the heat exchanger for inspection, maintenance, service, cleaning and disinfection.
- In case condensate is present, it is required by the designer of the air handling unit and/or duct system, to design and install a condensation tray according to the norm VDI 6022, chapter 4.3.16
- The casing is self-supporting but cannot take up extra load e.g. ducts.
- Place the rotor on a horizontal surface since an uneven surface can warp the casing and affect the factory adjustments.
- Make sure that the front- and back plates of the casing are installed perpendicular to the horizontal bottom surface. If not the casing may interfere with the movement of the rotor wheel.
- In case of horizontal rotors, support is needed for the frame and center girder. Also, check that rotor is ordered and manufactured as a horizontal rotor. Rotor may only be installed either in a vertical or a horizontal position according to design, not at an angle.
- Avoid diagonal flow since this can affect the rotation and drive of the wheel. Heatex AB recommends the airflow to be perpendicular to the rotor.
- The rotor is designed for counter flow only; co-current flow will decrease efficiency and reduce the rotors self-cleaning ability.
- Prior to initial operation, please make sure no objects are blocking the rotors movement. The rotor should move evenly and smoothly around its shaft.

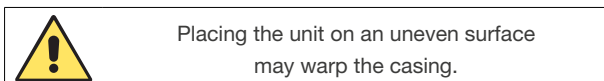

- Drive motor if delivered with controller is pre-wired and 230V should just be wired to the controller. Constant speed motors are without wiring. It is important that all electrical work is carried out by qualified staff. Please see enclosed documentation and/or wiring Picture 2.
- If the unit is delivered with a variable speed drive, read the corresponding controller documentation.

## 5. ADJUSTMENTS

- If necessary, adjust the brush sealants to minimize leakage.
- If the belt slides adjust belt tension.
- The round belt should have a tension of 4-6% and Powerbelt should have a tension of 1-2% (i.e. belt should be 1-2% shorter than the length it travels). For Powerbelt remove one link per meter belt to get correct tension

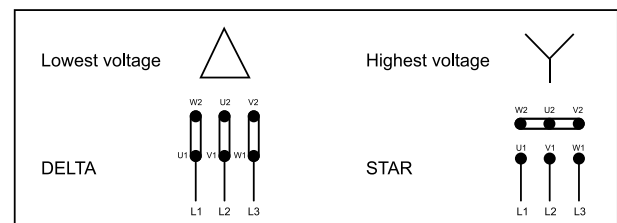
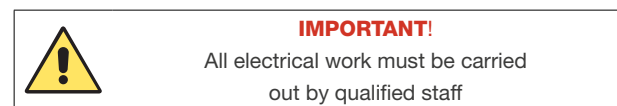

Picture 2. Wiring diagram constant drive  $\Delta/Y$  220/380V.

## 6. MAINTENANCE

### 6.1. Matrix

To secure the function and performance, the face of the rotor has to be inspected regularly for dust and dirt. In most cases, the rotor is self-cleaning due to counter flow and rotation of the matrix and this makes manual cleaning unnecessary. If the self-cleaning is insufficient dirt or/and dust can appear in the matrix. Depending on the degree of soiling it is recommended to use following cleaning.

1. For only a small amount of easily removable dirt, Heatex recommends to use a vacuum cleaner.
2. For heavier dirt it is also possible to use compressed air but with caution.
3. Firmly attached dirt in the rotor is easiest removed by using hot water and a mild detergent. The mild detergent may be removed with high-pressure water cleaner with the nozzle placed 100-200 mm from the matrix.
4. If required, Heatex recommends disinfection with the substance known as LIV +45.

### 6.2. Hybrid/Adsorption Material

The adsorption material is aluminum coated with a silica gel based coating. There is a small amount of surplus material that might leave the matrix during the first time of usage. This will NOT affect the hygroscopic properties. The excess powder is harmless and easy to remove using a vacuum cleaner.

The hybrid wheel properties are obtained by a combination of a flat strip of adsorption material consisting of silica gel coated aluminum and a corrugated aluminum strip, which result in a moisture transfer capacity in between that of an aluminum matrix and an adsorption matrix. Just as for the adsorption wheel, a small amount of surplus material may leave the matrix during the first time of usage.

### 6.3. Powerbelt

The Powerbelt is subject to natural stretching which may require shortening of the belt. Tension of the belt must be checked after the first 24-48 hours in operation to secure the rotational function of the wheel.

The belt is made of links that can easily be added or removed without any tools. By just twisting the belt, it is possible to open it and remove links to shorten the belt until correct length and belt tension is obtained. Belt tension should be 1-2% (i.e. belt length 1-2% shorter than travelled length). For Powerbelt remove one link per meter belt to get correct tension.

### 6.4. Round Belt

In addition, the round belt may need adjustment. When delivered from factory the belt is welded together. If adjustment is needed the belt must be cut, shortened and joined together again with a special joining pin. Belt tension should be 4-6%.

### 6.5. Brush Sealings

Tightness between brush sealants and casing has to be checked during inspection. The brush sealants are easily adjusted by unscrewing the screws and moving the brush sealant into the right position.

### 6.6. Controller

For further information regarding rotary heat exchanger equipped with controller, please see corresponding controller instructions.

## 6.7. Application Limits

Recommended temperature limits for rotary heat exchanger:

It is however important not to exceed the temperature limits on mounted components:

| Component           | Min           | Max           |
|---------------------|---------------|---------------|
| Bearings            | -40°C (-40°F) | 110°C (230°F) |
| Round belt          | -40°C (-40°F) | 66°C (150°F)  |
| Power belt          | -40°C (-40°F) | 110°C (230°F) |
| Motor *             | -20°C (4°F)   | 40°C (104°F)  |
| EMX-R controller    | -30°C (-22°F) | 40°C (104°F)  |
| Standard controller | 0°C (32°F)    | 45°C (113°F)  |

\* Thermo contacts release at 150°C (302°F) inner temperature.

Temperature inside casing is approximately the mean temperature of supply and exhaust air temperatures.

Recommended pressure drop and differential pressure for rotary heat exchanger:

- Pressure drop max 300 Pa (1.2" WC) during start up and maintenance.
- Recommended pressure drop 100-200 Pa (0.4-0.8" WC) during normal operation.
- Differential pressure max 600 Pa (2.4" WC).

## 6.8. Troubleshooting

If the rotary heat exchanger does not rotate properly, please follow these steps to solve/locate the problem.

1. If the motor runs properly, please jump to step 5.
2. If there is a controller installed please check controller technical specifications, chapter troubleshooting.
3. If there is a constant drive installed: Please check that the drive is correctly connected. Note that all electrical maintenance and installation must be performed by qualified personal.
4. Disconnect the belt, is the motor running correctly?
5. If the belt is sliding, please tighten the belt according to maintenance instruction.
6. Rotate the wheel by hand (belt disconnected from the motor). Is it possible to smoothly rotate the wheel or does the wheel interacts with the casing? If there is mechanical friction, please locate the position.
7. Make sure the connected ducts do not press on the casing making it squeeze against the wheel. Make sure the diagonal measures of the casing side where the motor is positioned are equal.



## 6.9. Conditions to Fulfill the Hygiene Certification Requirements

- Purge sector is required in order to make sure that less carry-over than 3% is reached.
- The AHU needs to be designed with hatches or openings towards all 4 open sides of the rotary heat exchanger. The heat exchanger itself has all 4 sides open according to the picture 3.
- All surfaces inside and outside of the rotor casing, especially the bottom surface and around the motor should be reachable for maintenance, cleaning and disinfection. Meaning that the openings or hatches mentioned in the item above need to be of sufficient size to fulfilling the cleaning and disinfection requirements.
- The AHU needs to be designed in such a way that the rotary heat exchanger is possible to slide out for cleaning and disinfection.
- Cleaning and disinfection of the heat exchanger should be done in accordance with Heatex cleaning and disinfection instructions with the cleaning and disinfection substances prescribed by Heatex.
- When condensation is present, the AHU installer needs to make sure that condensation trays are installed beneath the heat exchanger. These trays need regular inspection, cleaning and disinfection.
- The trays should be designed and installed with sufficient drainage in accordance with the hygiene standard VDI 6022, chapter 4.3.16.
- The heat exchangers are not certified for installation in exhaust classes ETA 3 and ETA 4 according to EN 13779 (09/2007).

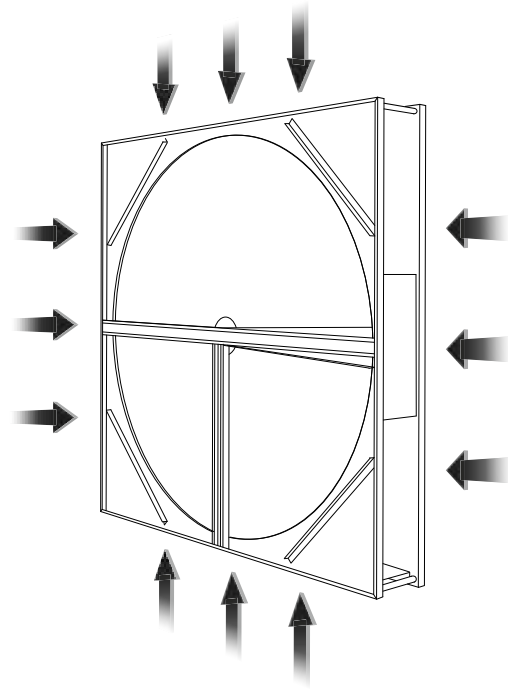

Picture 3. All 4 sides are open on the heat exchanger. The AHU designer and installer need to have openings or hatches on all of these 4 sides in the AHU for easy access during maintenance, cleaning and disinfection of the heat exchanger.

## 7. SUPPORT

For questions or information regarding this product, please communicate your order number and product code along with your message.

Heatex is available for support during office hours: 8 am – 4.30 pm (GMT +1) on weekdays.

